

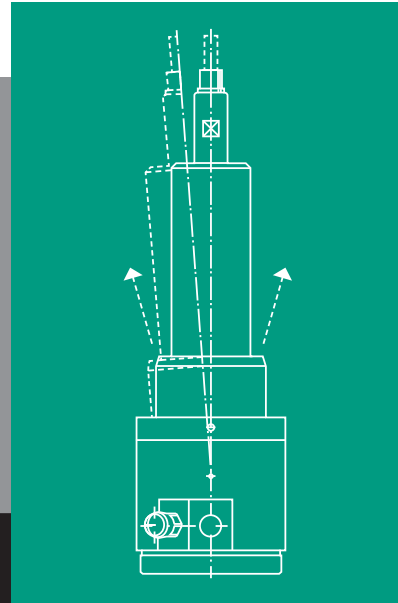

**BIAX**  
Professional Power

**PNEUMATIC TOOLS FOR  
PROFESSIONALS:  
GRINDING SPINDLES AND  
ROBOT TOOLS**

**Tough • Consistent • Proven**



**Das Original**





Production hall Maulbronn plant

**The house of Schmid & Wezel has been renowned for the highest level of precision, quality and partnership for over 95 years.**

The three divisions of the company include BIAX pneumatic and electric tools, BIAX tungsten carbide tools and EFA meat processing machinery. These are manufactured in three modern production sites in Germany and Switzerland. The Maschinenfabrik Schmid & Wezel products make it the quality leader in the market, not least due to the high vertical manufacturing integration of up to 90%.

Sustainable customer satisfaction is our goal and the vital driving force for continuous innovation and quality. The strengths of Schmid & Wezel are tailored solutions in high product quality and individual customer service.

Schmid & Wezel is ISO certified:



BIAX Maulbronn



BIAX Hilsbach



## Table of contents

Page	
4-5	Pneumatic grinding spindles with vane motor
6	Pneumatic grinding spindles with oil-free turbine motor
7	Pneumatic grinding spindles with oil-free vane motor
8	Pneumatic spindles for brushing and drilling
9	Pneumatic spindles with angle head
10	Pneumatic drilling deburrer
11	Pneumatic drilling deburrer with angle head
12-13	Oscillating drives
14-15	RSC modular system
16	RSC modular system for robot machining
17	RSC modular system for CNC machining
18-19	Pneumatic spindles with deflection (pneumatic)
19	Collets



## Grinding spindles and robot tools

BIAX is the world leader in compressed air spindles for automation. From simple stationary spindles at various speeds (also with oil-free motors), through filers and drill deburrers, to spindles with deflection and quick-change systems: You can draw from an inexhaustible pool of stationary pneumatic tools. The quality and reliability of the components play a major role in particular in automation solutions. BIAX pneumatic spindles have demonstrated in a variety of installations throughout the world that they are among the best on the market and more than capable of meeting quality requirements.

BIAX have worked for many years with specialized system integrators who have successfully automated countless deburring projects. If you are looking for a total solution we would be happy to recommend our proven partner.

At BIAX we use a test robot (Fanuc M10ia) to put our components through stringent trials. This puts us in the position to give our customers well-founded advice and investigate difficult tasks. Contact us. We look forward to hearing from you.



# PNEUMATIC GRINDING SPINDLES

with vane motor. Operation with lubricated compressed air (6 bar)!

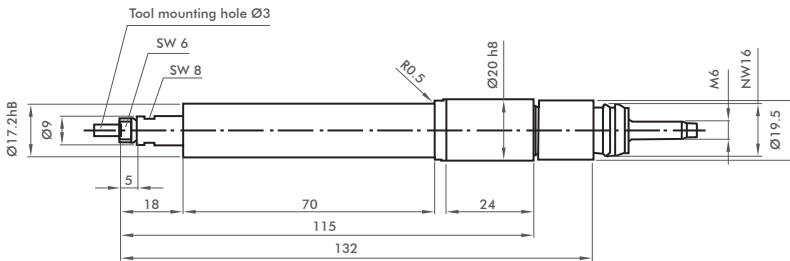

## RO 1785

The high speed and concentricity of this spindle produces a very clean grinding pattern and it is therefore ideally suited for fine grinding, milling and engraving. The paired heavy duty bearings ensure long service life. This model includes the BIAx hose unit with silencer.

Also available:

- Different collets up to  $\varnothing 3$  mm (see P. 19)

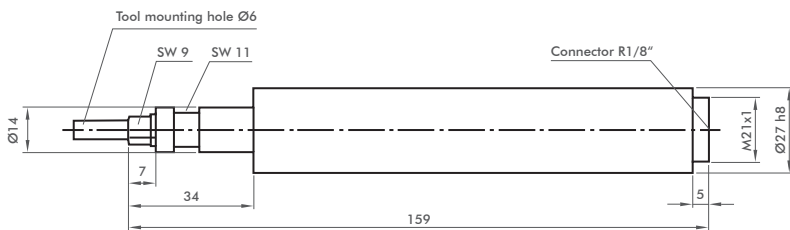

## R 2732

This spindle is designed to be very compact, yet has enough power for light grinding and milling.

Also available:

- Different collets up to  $\varnothing 6$  mm (see P. 19)
- BIAx hose unit (3 m): reduces noise and guides compressed air in a controlled manner (Order no. 001 366 529)
- Splash guard and counterclockwise rotation

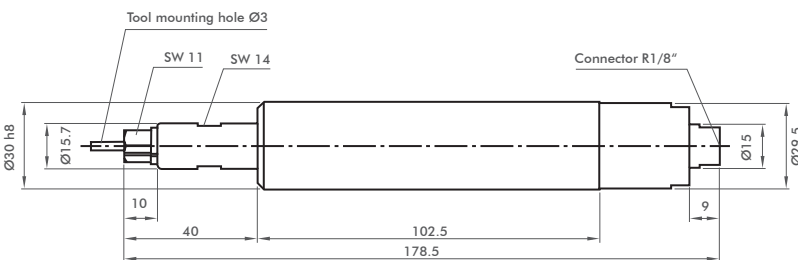

## R 3030 / R 3040

These two spindles are equipped with a more powerful motor than the R 2732 and are therefore designed for higher loads.

Also available:

- Different collets up to  $\varnothing 8$  mm (see P. 19)
- BIAx hose unit (3 m): reduces noise and guides compressed air in a controlled manner (Order no. 001 366 505)
- Splash guard and counterclockwise rotation

## R 3622

This spindle guarantees a high stock removal. The power of this spindle is sufficient to drive carbide tools up to 12 mm and profile grinding wheels up to 24 mm.

Also available:

- Different collets up to  $\varnothing$  8 mm (see P. 19)
- BIAx hose unit (3 m): reduces noise and guides compressed air in a controlled manner (Order no. 001 366 505)
- Splash guard and counterclockwise rotation

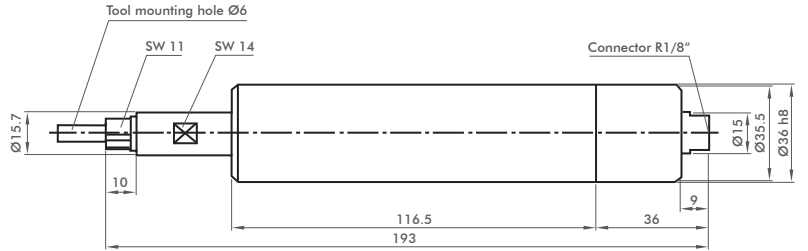

## R 4112

with its 12,000 rpm this spindle is particularly suitable for tools that require high torque at low speed. At 400 watts this is our most powerful milling and grinding spindle.

Also available:

- Different collets up to  $\varnothing$  10 mm (see P. 19)
- BIAx hose unit (3 m): reduces noise and guides compressed air in a controlled manner (Order no. 001 366 580)

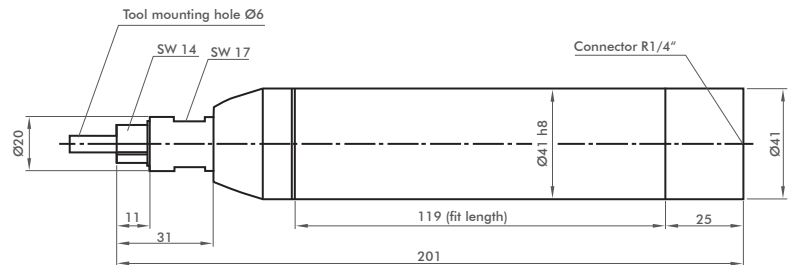

Designation	RO 1785	R 2732	R 3030	R 3040	R 3622	R 4112
Order number	150 401 202	150 412 702	150 414 110	150 414 120	150 425 210	150 414 520
Speed [rpm]:	85,000	32,000	30,000	40,000	22,000	12,000
Power [Watt]:	100	200	240	240	300	400
Front bearing	Paired	Paired	Paired	Paired	Double	Single
Collet type [mm]:	ZG 5/3	ZG 4/6	ZG 7/6	ZG 7/6	ZG 7/6	ZG 8/6
Exhaust air direction	Backwards	Backwards	Backwards	Backwards	Backwards	Backwards
Max. collet diameter [mm]:	3	6	8	8	8	10
Max. tool diameter						
Carbide tools [mm]:	4	8	10	8	12	15
Profile grinding wheels [mm]:	6	12	16	10	24	24
Air consumption under load [l / min]:	180	400	400	400	500	790
Noise level [dB (A)]	70	75	75	76	73	78
Weight [g]	200	365	420	420	640	750
Connection thread	M 6 external	R 1/8"	R 1/8"	R 1/8"	R 1/8"	R 1/4"
Hose unit						
Order number	001 366 595	001 366 529	001 366 505	001 366 505	001 366 505	001 366 580
Hose length [m]:	1.5	3	3	3	3	3
Air hose diameter [mm]:	4.5	7	7	7	7	10
Hose unit included	yes	no	no	no	no	no

# PNEUMATIC GRINDING SPINDLES

## with oil-free turbine motor (6 bar)

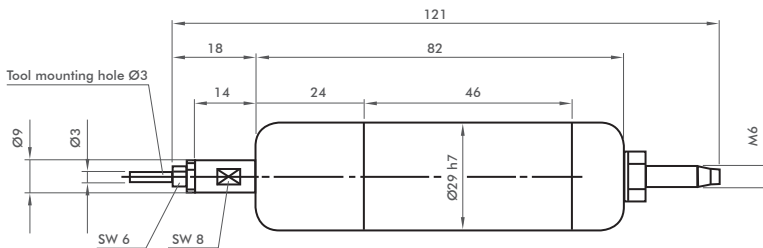

### T 29-100

This high-speed spindle is particularly suitable for the use with the finest milling and grinding tools. The elastic front bearing enables the production of surfaces of the highest quality. A further application is the drilling of rubber.

Also available:

- Different collets up to Ø 3 mm (see P. 19)
- Hose unit (1.5 m): (Order no. 001 366 537)

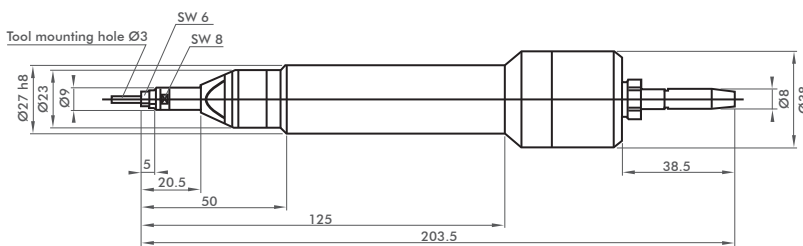

### T 27-65

This spindle is ideal for fine grinding, milling and engraving surfaces that must not be oil lubricated. The centrifugal governor ensures constant speed and reduces air consumption.

Also available:

- Different collets up to Ø 3 mm (see P. 19)
- Hose unit (3 m): (Order no. 001 366 502)

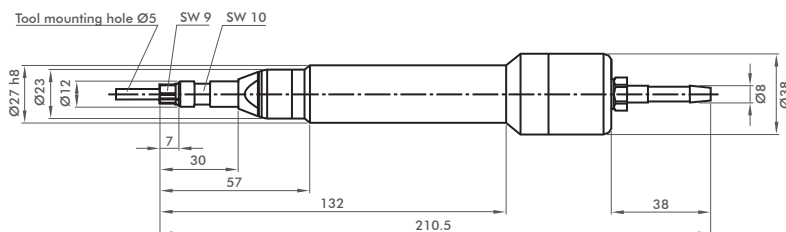

### T 27-40

Model T 27-40 with its reduced speed of 40,000 rpm at 3 bar is particularly suitable for drilling rubber. Drills of up to 5mm diameter can be used for this application.

Also available:

- Different collets up to Ø 5 mm (see P. 19)
- Hose unit (3 m): (Order no. 001 366 502)

## with oil-free vane motor (6 bar)

### TR 1785

The lubricant-free drive of this grinding spindle based on a vane motor is unique and patented. Its great advantage: It provides the high performance of a vane motor and can still work completely lubrication-free. This model includes the BIAx hose unit with silencer.

Also available:

- Different collets up to  $\varnothing 3$  mm (see P. 19)

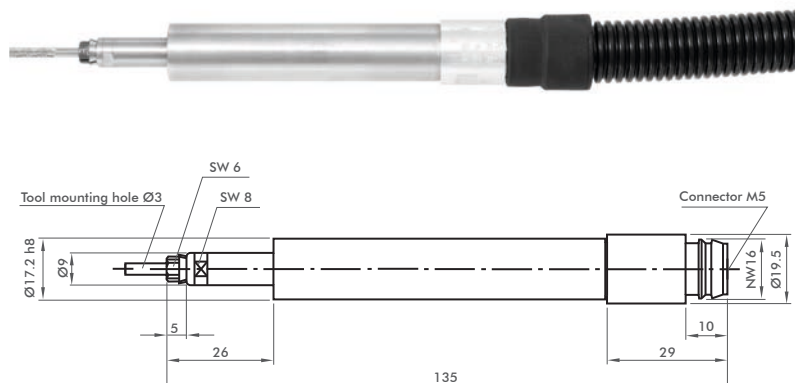

### The main benefits at a glance:

- The oil-free operation means that there is no oil mist on the workpieces.
- High speeds, tailored to each tool, guarantee a perfect grinding and milling pattern.
- High concentricity
- Low noise
- **Turbine motor:** The turbine grinders T 29 - 100, T 27 - 40 and T 27 - 65 are planned and designed to be particularly resistant to wear and give a long service life.
- **Oil free vane motor:** Achieves the high performance of a vane motor but operates absolutely lubrication-free. This is unique and patented.

Designation	T 29-100	T 27-65	T 27-40	TR 1785
Motor type	Oil free turbine motor	Oil free turbine motor	Oil free turbine motor	Oil free vane motor
Order number	150 420 100	150 420 200	150 420 210	150 401 400
Speed [rpm]:	100,000	65,000	40,000	85,000
Power [Watt]:	80			100
Front bearing	Single	Single	Paired	Paired
Collet type [mm]:	ZG 5/3	ZG 5/3	ZG 4/5	ZG 5/3
Max. collet diameter [mm]:	3	3	5	3
Max. tool diameter				
Carbide tools [mm]:	3	6	5	4
Profile grinding wheels [mm]:	5	8	10	6
Exhaust air direction	Forwards	Backwards	Backwards	Backwards
Air consumption under load [l / min]:	180	180	180	170
Noise level [dB (A)]:	70	70	70	70
Weight [g]	290	485	510	130
Connection thread	R 1/8"	R 1/8"	R 1/8"	M5
Hose unit				
Order number	001 366 537	001 366 502	001 366 502	001 366 576
Hose length [m]:	1.5	3	3	1.5
Air hose diameter [mm]:	4.5	7	7	4.5
Hose unit included	no	no	no	yes

# PNEUMATIC SPINDLES

for brushing and drilling. Operation with lubricated compressed air (6 bar)!



## R 4102 / R 4105

These spindles are particularly suitable for brushing and drilling as they are equipped with a particularly high-torque motor. The integrated gearing reduces the speed and increases the torque.

Also available:

- Different collets up to  $\varnothing$  10 mm (see P. 19)
- BIAx hose unit (3 m): reduces noise and guides compressed air in a controlled manner (Order no. 001 366 510)

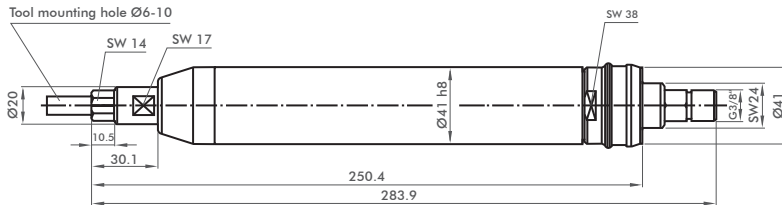

## RB 4102

The RB 4102 with 1,700 rpm has been specially equipped for drilling with a drill chuck. Tool shanks of up to 10 mm can be clamped infinitely variably. The drilling and brushing spindles are equipped with double-row bearings that are able to withstand the high forces.

Also available:

- BIAx hose unit (3 m): reduces noise and guides compressed air in a controlled manner (Order no. 001 366 510)

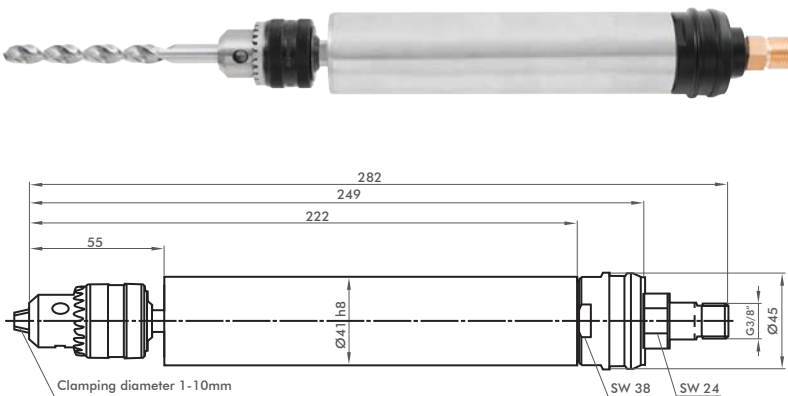

Designation	R 4102	R 4105	RB 4102
Order number	150 414 540	150 414 530	150 414 545
Speed [rpm]:	1,700	5,000	1,700
Power [Watt]:	500	500	500
Front bearing	Double-row	Double-row	Double-row
Collet type [mm]:	ZG 8/6	ZG 8/6	Chuck 1-10
Exhaust air direction	Backwards	Backwards	Backwards
Max. collet diameter [mm]:	10	10	10
Max. tool diameter	-	-	-
Air consumption under load [l / min]:	850	850	850
Noise level [dB (A)]:	83	83	83
Weight [g]	1,400	1,400	1,700
Connection thread	G 3/8"	G 3/8"	G 3/8"
<b>Hose unit</b>			
Order number	001 366 510	001 366 510	001 366 510
Hose length [m]:	3	3	3
Air hose diameter [mm]:	10	10	10
Hose unit included	no	no	no



# PNEUMATIC SPINDLES

with angle head. Operation with lubricated compressed air (6 bar)!

## WR 620/2 R

This angle spindle is suitable for surface finishing and deburring hard to reach places. The robust gearbox and the double bearings make this spindle extremely wear resistant despite its small size.

Also available:

- Different collets up to  $\varnothing$  6 mm (see P. 19)
- BIAX hose unit (3 m): reduces noise and guides compressed air in a controlled manner (Order no. 001 366 505)

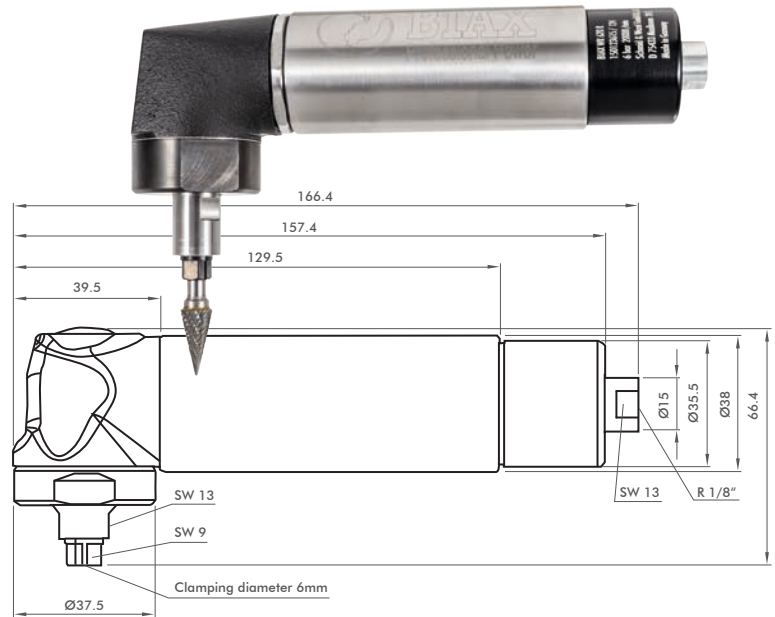

## WR 620 R ZL 90

This version can help in really tight places. With the same speed, but with an extended neck and significantly slimmer head, this version can reach into the narrowest positions.

Also available:

- Different collets up to  $\varnothing$  6 mm (see P. 19)
- BIAX hose unit (3 m): reduces noise and guides compressed air in a controlled manner (Order no. 001 366 505)

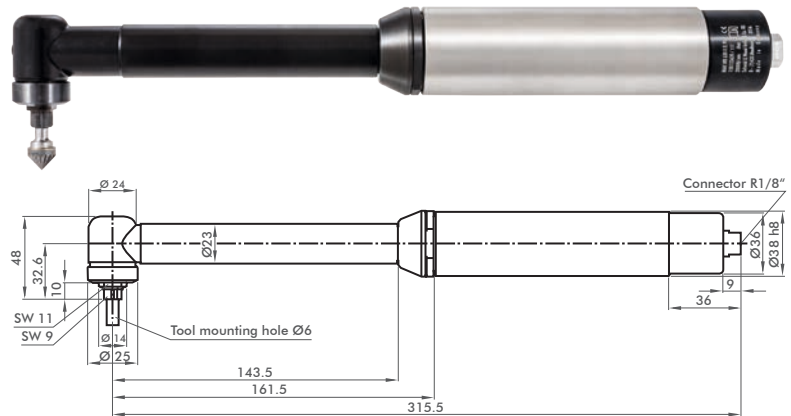

Designation	WR 620/2 R	WR 620 R ZL 90
Order number	150 123 616	150 123 620
Speed [rpm]:	20,000	20.000
Power [Watt]:	300	300
Front bearing	Double	Double
Collet type [mm]:	ZG 4/6 mm	ZG 4/6 mm
Exhaust air direction	Backwards	Backwards
Max. collet diameter [mm]:	6	6
Max. tool diameter	-	-
Carbide tools [mm]:	12	12
Profile grinding wheels [mm]:	24	24
Air consumption under load [l / min]:	500	500
Noise level [dB (A)]:	74	78
Weight [g]	770	930
Connection thread	R1/8"	R1/8"
Hose unit		
Order number	001 366 505	001 366 505
Hose length [m]:	3	3
Air hose diameter [mm]:	8	8
Hose unit included	no	no

# PNEUMATIC DRILL DEBURRER

for deburring and countersinking holes. Operation with lubricated compressed air (6 bar)!

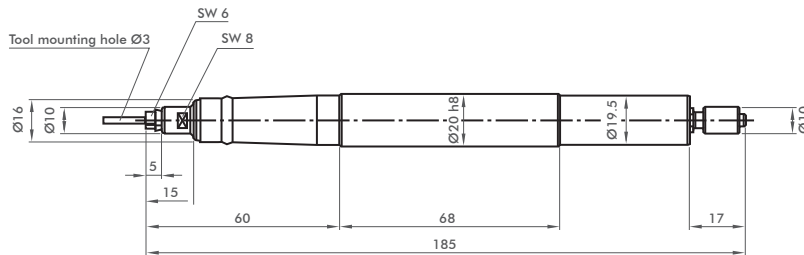

## BE 309 R / BE 309 R-2

This drill deburrer can be used to deburr holes up to a  $\varnothing$  of 5.5 mm. The version BE 309 R features a push start whereas the version BE 309 R-2 is switched on and off using the supply air. The BIAx hose unit is included with this model.

Also available:

- Different collets up to  $\varnothing$  3 mm (see P. 19)
  - Countersink range  $\varnothing$  2-5.5 mm
- Order no. HSS 001 950 292

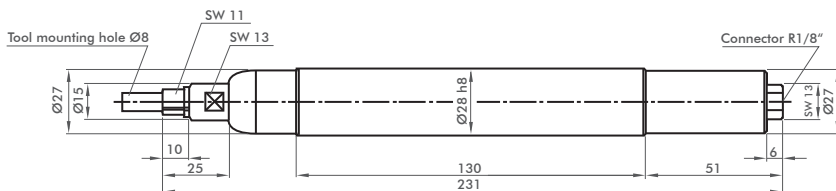

## BE 805 R / BE 805 R-2

This drill deburrer can be used to deburr holes up to a  $\varnothing$  of 24 mm. The version BE 805 R features a push start whereas the version BE 805 R-2 is switched on and off using the supply air. The BIAx hose unit is included with this model.

Also available:

- Different collets up to  $\varnothing$  8 mm (see P. 19)
  - Countersink range  $\varnothing$  3.5-14 mm
- Order no. HSS 001 950 290
- Countersink range  $\varnothing$  5-24 mm
- Order no. HSS 001 950 291

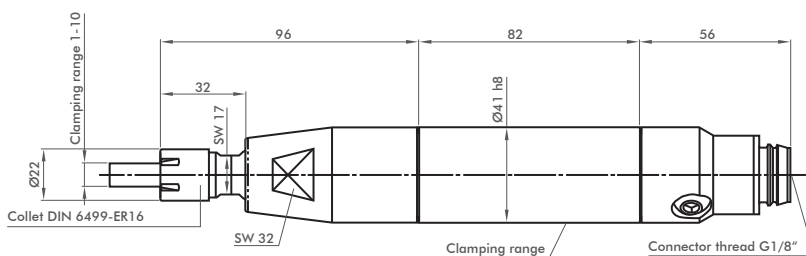

## BE 1005 R

With a countersinking diameter of up to 29 mm and a speed of 550 rpm the BE 1005 R is our biggest and most powerful drill deburrer. The spindle is switched on and off via the supply air.

Also available:

- BIAx hose unit (3 m): reduces noise and guides compressed air in a controlled manner (Order no. 001 366 578)
  - Countersink range  $\varnothing$  6-29 mm
- Order no. HSS 001 950 341

# PNEUMATIC DRILL DEBURRER

with angle head. Operation with lubricated compressed air (6 bar)!

## BEW 309 R-1

Our top device when it comes to deburring holes in difficult to reach areas. The height of the drive head is only 20,5 respectively 21,5 mm (depending on the countersink version). The drive can be adjusted in the range of 0-900 rpm. The BIAx hose unit and an HSS countersink  $\varnothing$  2-6 mm are included with this model.

Also available:

- Countersink range  $\varnothing$  2-6 mm  
Order no. HSS 001 950 293 (incl.)  
Order no. HM 001 950 299
- Countersink range  $\varnothing$  2.5-10 mm  
Order no. HSS 001 950 297

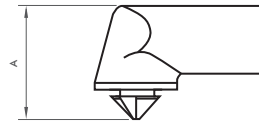
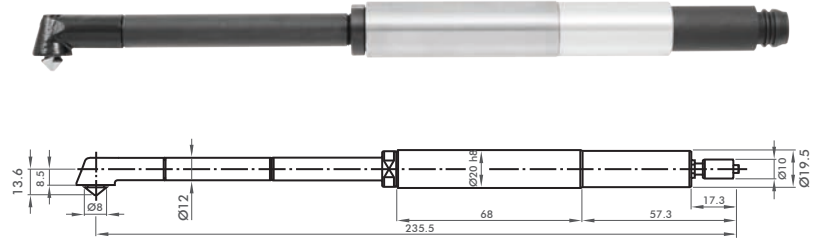

## BEW 605 R

This machine has an angular design which allows the deburring of holes in difficult to reach areas up to a countersinking diameter of 24 mm. Typically these are holes with transverse bores. The BIAx hose unit is included with this model.

Also available:

- Countersink range  $\varnothing$  3.5-14 mm  
Order no. HSS 001 950 295
- Countersink range  $\varnothing$  5-24 mm  
Order no. HSS 001 950 296

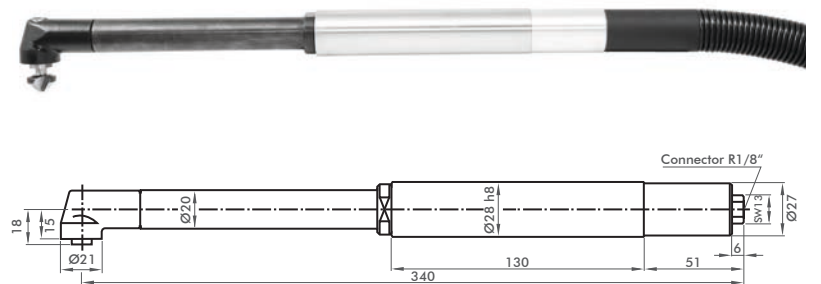

Designation	BE 309 R	BE 309 R-2	BE 805 R	BE 805 R-2	BE 1005 R	BEW 309 R-1	BEW 605 R
Order number	150 800 715	150 800 705	150 810 905	150 810 920	150 800 810	150 800 740	150 810 935
Speed [rpm]:	900	900	500	500	550	900	500
Start	Push start	external	Push start	external	external	external	external
Exhaust air direction	Backwards	Backwards	Backwards	Backwards	Backwards	Backwards	Backwards
Air consumption [l/min]:	150	150	300	300	480	150	300
Collet type [mm]:	ZG 5/3 mm	ZG 5/3 mm	ZG 7/8 mm	ZG 7/8 mm	ER 10 mm	-	-
Noise level [dB (A)]:	71	71	71	71	78	71	71
Weight [g]	195	195	570	570	1,370	340	800
Max. collet diameter [mm]:	3	3	8	8	10	-	-
Sink diameter min./max [mm]:	2-5.5	2-5.5	3.5-24	3.5-24	6-29	2-6   2.5-10	3.5-14   5-24
Max tool holder [mm]:	-	-	-	-	$\varnothing$ 6	3mm / 6 hex	$\varnothing$ 6
Head A at sink - $\varnothing$ min./max [mm]:	-	-	-	-	-	20.5   21.5	40   48
Angle head diameter	-	-	-	-	-	14	21
<b>Hose unit</b>							
Order number	001 366 549	001 366 549	001 366 548	001 366 548	001 366 578	001 366 549	001 366 548
Hose length [m]:	1.5	1.5	1.5	1.5	3	1.5	1.5
Air hose diameter [mm]:	4.5	4.5	7	7	7	4.5	7
Hose unit included	yes	yes	yes	yes	no	yes (pressure hose)	yes

# OSCILLATING DRIVES

with swash plate drive. Operation with lubricated compressed air (6 bar)!

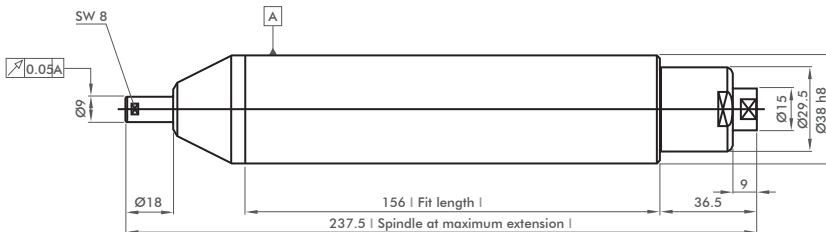
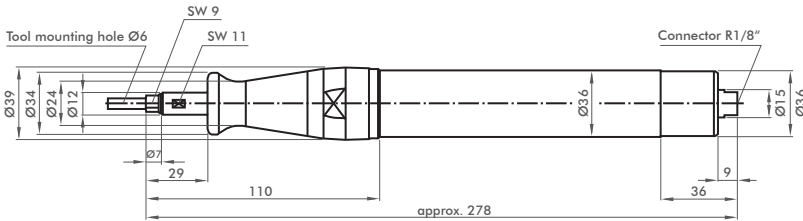

## FR 8-2 R

This is exactly the right drive where ever a long, high torque stroke is needed. The swash plate drive enables the stroke length to remain constant even under extreme loads. Tools with shafts up to  $\varnothing 6$  mm can be used.

Also available:

- Different collets up to  $\varnothing 6$  mm (see P. 19)
- BIAx hose unit (3 m): reduces noise and guides compressed air in a controlled manner (Order no. 001 366 505)
- Matching files can be found in our "Accessories" catalogue or under [www.biax.de](http://www.biax.de)

## F 5-4 R

This oscillating drive is distinguished by its small stroke combined with high torque. The stroke length is adjustable and remains constant even under high loads. The drive is also available with a fixed stroke of 2 mm (Order no. 150 310 830) or 3 mm (Order no. 150 310 825).

Also available:

- Different collets up to  $\varnothing 3$  mm (see P. 19)
- BIAx hose: reduces noise and guides compressed air in a controlled manner (Order no. 001 366 505)
- Matching files can be found in our "Accessories" catalogue or under [www.biax.de](http://www.biax.de)

Designation	FR 8-2 R	F 5-4 R
Order number	150 322 613	150 310 820
Stroke number [rpm]:	2,000	4,000
Stroke length [mm]:	8	1-5 infinitely adjustable
Drive type	Vane motor	Vane motor
Collet type [mm]:	ZG 4/6 mm	ZG 5/3 mm
Max. collet diameter [mm]:	6	3
Exhaust air direction	Backwards	Backwards
Weight [g]	1,300	960
Suitable hose unit	001 366 505	001 366 505

# OSCILLATING DRIVES

with a piston motor. Operation with lubricated compressed air (6-8 bar)!

## AG 90

This powerful multi-purpose device is perfectly designed for filing, sawing, polishing and cutting. The low-wear piston motor is characterized by its high number of strokes. It is capable of 12,000 strokes per minute at a maximum stroke length of 9 mm. Both can be adjusted by the user, which makes this machine extremely adaptable.

Also available:

- Tool holder with clamping diameter 3 mm (Order no. 001 974 430), 4 mm (installed, Order no. 001 974 411), 6 mm (Order no. 001 974 443)
- BIAx air supply hose with connectors (Order no. 001 974 552)
- Matching files can be found in our "Accessories" catalogue or under [www.biax.de](http://www.biax.de)

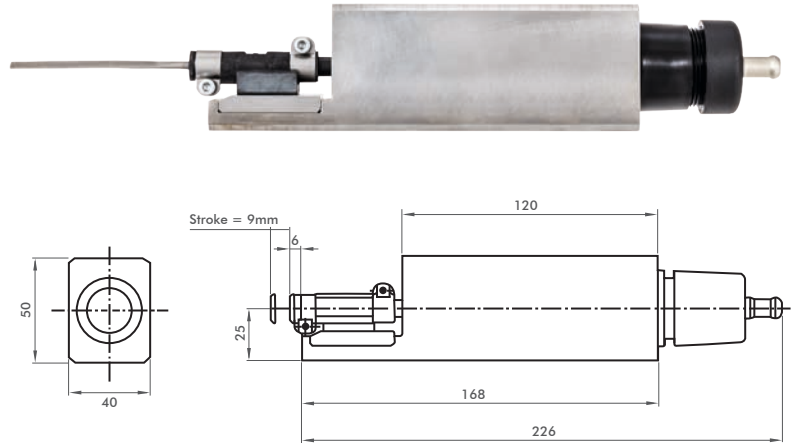

## PLV 01

Despite its stroke length of 8 mm and stroke rate of 12,000 rpm this unit produces virtually no vibration (patented vibration damping). The aluminium housing makes this machine particularly light. All around pre-drilled holes allow rapid adaptation. Included in the delivery is a tool holder with clamping diameter 3 mm (Order no. 001 974 430), 4 mm (Order no. 001 974 411), 6 mm (Order no. 001 974 443) and an exhaust hose for noise suppression.

Also available:

- BIAx air supply hose with connectors (Order no. 001 974 552)
- Matching files can be found in our "Accessories" catalogue or under [www.biax.de](http://www.biax.de)

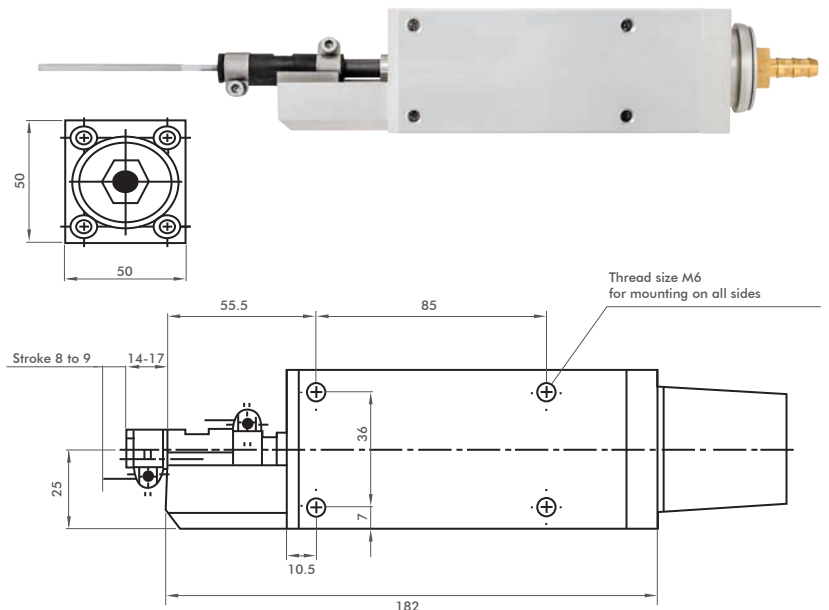

Designation	AG 90	PLV 01
Order number	150 310 900	150 310 910
Stroke number [rpm]:	to 12,000	12,000
Stroke length [mm]:	2-9	8-9 (6-8 bar)
	infinitely adjustable	
Drive type	Piston	Piston
Max. collet diameter [mm]:	6	6
Exhaust air direction	Backwards	Backwards
Weight [g]	1,900	1,200
Suitable hose unit	001 974 552	001 974 552

# RSC MODULAR SYSTEM

## The spindle packages

Properties	RSC-S 16000	RSC-S 20000
Motor type	Vane motor	Vane motor
Order no.	008 010 271	008 012 883
Speed/stroke	16.000 (rpm)	20.000 (rpm)
Collet type	ZG8	ZG7
Air consumption (l/min)	800	600
Power [Watt]	550	350

## The system

Whether rigid or with deflection, whether rotating or oscillating, whether on a robot or machining centre, all applications using one single system. This is unique. As the name suggests, our new spindle system is completely modular and can be configured in simple steps for the appropriate application. All components are interchangeable, giving you maximum flexibility. Contact us, we will help you to compile the right package. Further information on use with robots or in a machining centre is given on pages 16-17.



## The extension (Order no. 007 013 402)

An extension of 150 mm can be used between the coupling and spindle package. This enables the most difficult places to be reached.



## The attachments

Properties	RSC-A U	RSC-A W	RSC-A HSK-A-100
Description	Universal adapter	Weldon adapter	HSK-A-100 Adapter
Order no.	003 012 895	003 013 505	001 626 014

RSC-S 30000	RSC-S 40000	RSC-S 85000	RSC-S 100000	RSC-S 20000 W90-1	RSC-PLV
Vane motor	Vane motor	Vane motor	Turbine (oil-free)	Vane motor	Piston motor
008 006 506	008 012 874	008 013 512	008 013 508	008 012 890	-
30.000 (rpm)	40.000 (rpm)	85.000 (rpm)	100.000 (rpm)	20.000 (rpm)	12.000 (rpm)
ZG7	ZG7	ZG5	ZG5	ZG4	4 mm
450	450	200	200	600	300
255	300	58	25	350	-



### The spindle packages

Available for selection are straight spindles in different speeds as well as angled versions. An oscillating operation is also available. The spindle packages can be changed in a few simple steps. This enables maintenance intervals or modifications to be carried out inexpensively and simply. A selection of our spindles can be found above. On request spindles can also be supplied in counterclockwise and with an ER collet.



### The coupling (Order no. 007 012 878)

The coupling is the heart of the system and is always part of the equipment. It receives the spindle packages and combines them with a connection or deflection. The coupling also enables the system to be supplied with compressed air from the side.



### The deflection (Order no. 007 014 003)

Depending on the application, the system can be made rigid or radially deflected. The deflection unit is mounted in only a few steps between the coupling and connection and immediately converts the rigid system to a flexible system. The deflection force can be adjusted using the adjusting ring between approximately 15 and 120 Newton. The deflection is achieved by internal spring sets. The maximal deflection is approximately 12 mm, depending on the length of the tool.



### The attachments

We have the perfect attachments in our programme for many applications. For the machining centres we offer the standard machine tools attachments such as HSK and SK and a Weldon adapter. These mountings also enable compressed air supply through the coolant channel. Universal adapters are available for stationary mounting or mounting to a robot. Also available is the Schunk change system, which allows the spindle to be changed in process.

RSC-A HSK-A-63	RSC-A SK50	RSC-A SK40	RSC-A Sch
HSK-A-63 Adapter	SK50 Adapter	SK40 Adapter	Schunk quick-change system
001 626 015	001 626 017	001 626 016	008 012 881

# RSC MODULAR SYSTEM

## for robot machining

The main application of the RSC system is the deburring and finishing of components. This is often performed together with an industrial robot. The RSC system is the perfect spindle system for this application. The correct configuration is available for almost all types of finishing. We would be happy to advise you.



### Example of use: Deburring castings.

Due to the high component tolerances and positional inaccuracy often encountered with cast parts, in many cases it is necessary for the system to have deflection capability. Only then is it still possible to ensure uniform removal. The fixed version can be used where parts are precisely machined and positioning is very accurate. The RSC system can do both. We can assist you in selecting the right configuration.



### Example of use: Deburring of fibre composites.

The oscillating spindle insert RSC-PLV with deflection is particularly suited for deburring fibre composites. It is also very capable of performing very fine deburring work on all types of parts. Deburring angled transitions is also part of its capabilities.

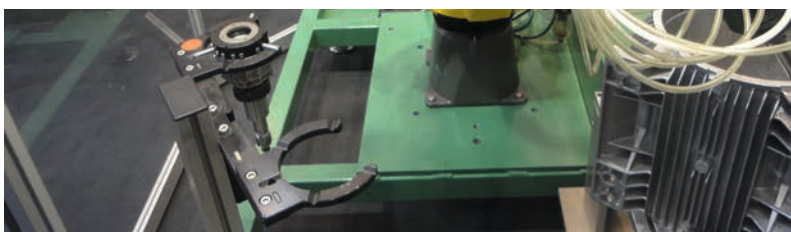

Example: Spindle storage and changing system



Example: Robot mounted system

## Mounting options

The RSC system can be used as both a stationary system (the part is guided to the spindle), and also mounted directly on the robot (the easiest method is using our universal adapter RSC-A U). Their small size enables several spindles to be easily mounted directly on the robot, as you can see in our example. The programme also includes a spindle changing system, (RSC-A Sch), which allows you to change the spindles in process.



# RSC MODULAR SYSTEM

## for CNC machining

Our RSC system can be used in machining centres.

In this application the RSC system provides three distinct advantages:

- The system is capable of speeds (up to 100,000 rpm), which are in excess of the majority of machining centres.
- The deflection capability enables the clean machining of undefined contours.
- They protect your machining centre as it does not need to operate at its speed limit.



Whether you use a HSK or SK mount, we have the most common types of mounting in our programme. If you need a mounting that we do not currently offer please contact us. The RSC system can be driven with compressed air through the internal coolant system of the CNC machine. There is no requirement for manually installing any hoses or cables.



### Applications: Deburring, engraving, polishing, detailed fine milling

The high speed of the spindles enable deburring to be performed quickly and economically. The deflection capability also enables undefined contours to be machined cleanly. In the rigid version the system can be used for engraving and fine detailed milling. Again, the high speeds play an important role. Polishing directly after milling saves significant manual work. Deflection allows the polishing tool to always maintain constant force on the surface. The result is a consistently high surface quality.



### Example: RSC system in the magazine of a CNC machine

The system can be placed in the machine magazine of a CNC machine and changes made fully automatically. No manual steps necessary when setting the system to work.

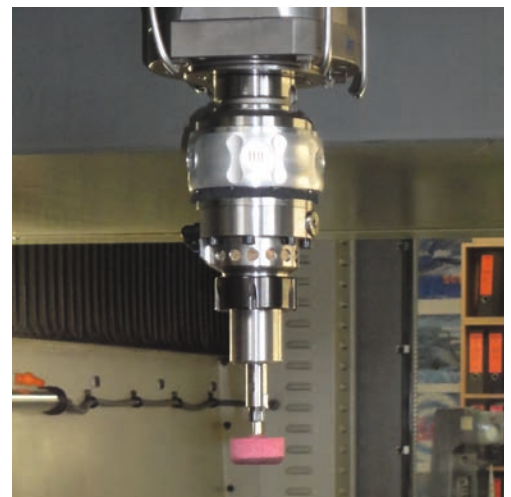

Example: RSC system in a machining centre

# PNEUMATIC SPINDLES

with deflection (pneumatically controlled). Operation with lubricated compressed air (6 bar)!

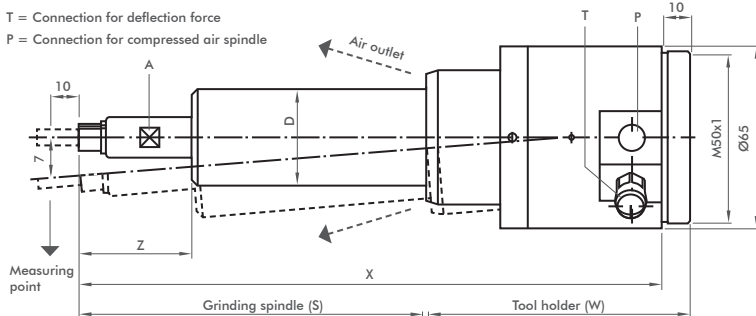

## RWA

This deflectable pneumatic spindle is capable of compensating part and positioning tolerances when machining. This means that it is possible to trace a part contour with constant pressure and achieve uniform removal, even under fluctuating conditions. An optimum application for this system is, for example, the automated deburring of castings or machined components using an industrial robot. Adaptor flange (Order no. 003 012 557) to simplify the mounting of the system is available directly from us.

Table for the deflection system:

RWA 5-12 with spindle running	
Deflection force at the measuring point 1 with the spindle running	
Air pressure	Force
2 bar	26 N
3 bar	38 N
4 bar	50 N
5 bar	62 N
6 bar	70 N

Table for the deflection systems:

RWA 2-40, RWA 2-30, RWA 2-22, RWA 2-24	
Deflection force at the measuring point 1 with the spindle running	
Air pressure	Force
2 bar	12 N
3 bar	20 N
4 bar	24 N
5 bar	28 N
6 bar	32 N

The deflection force is individually infinitely adjustable using air pressure (2-6 bar), even during processing. This enables the removal rate to be perfectly adapted to the thickness of the burr. After deflection the pressurized air piston always returns the tool to the zero position against a positive stop. Hysteresis zero.

Designation	RWA 2-40	RWA 2-30	RWA 2-22	RWA 5-12
Installed grinding spindle	R 3040	R 3030	R 3622	R 4112
Order number	150 830 835	150 830 820	150 830 825	150 830 885
Speed [rpm]:	40,000	30,000	22,000	12,000
Power [Watt]:	240	240	300	400
Noise level [dB (A)]:	75	75	73	79
Max. collet diameter [mm]:	8	8	8	10
Collet type [mm]:	ZG 7/6	ZG 7/6	ZG 7/6	ZG 8/6
Direction of rotation	Clockwise	Clockwise	Clockwise	Clockwise
Exhaust air direction	Forwards	Forwards	Forwards	Forwards
Weight [g]:	1,520	1,535	1,850	2,320
Air connection	R1/8"	R1/8"	R1/8"	R1/4"
Total L dimension X [mm]:	193	193	207	263
Grinding spindle L dimension S [mm]:	110	110	124	176
Tool holder L dimension W [mm]:	83	83	83	87
Spindle L dimension Z [mm]:	41	41	41	31
Spindle diameter dimension D [mm]:	30	30	36	41

## with deflection and quick-change system

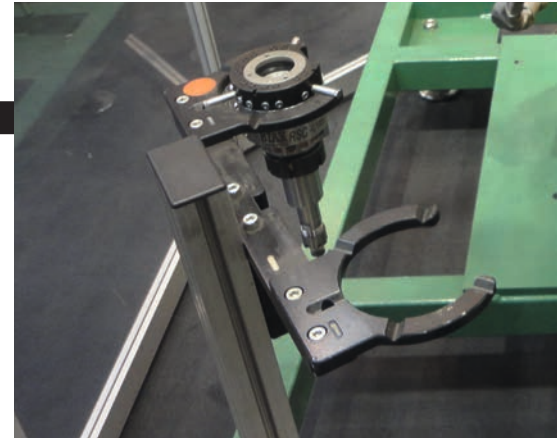

Example: Spindle storage

### BWS 2-22

This change system enables fast replacement of spindles in robot cells. Stationary clamped parts can then be machined using different spindles and only one robot. On request spindles are also available with 12,000 rpm (Order no. 150 830 900), 30,000 (Order no. 150 830 960), and 40,000 (Order no. 150 830 980) revolutions per minute.

Tool changer

Designation	BWS 2-22	SWK 020
Installed grinding spindle	R 3622	
Order number	150 830 940	001 626 003
Speed [rpm]:	22,000	
Power [Watt]:	300	
Max. collet diameter [mm]:	8	
Collet type [mm]:	ZG 7/6	
Direction of rotation	Clockwise	
Exhaust air direction	Forwards	
Weight [g]	2,400	
Air connection	Robot side	

## COLLETS

Type	ZG 1	ZG 1 A	ZG 4	ZG 5	ZG 7	ZG 8
	Order no.	Order no.	Order no.	Order no.	Order no.	Order no.
Hole 0.5 mm	-	-	-	001 999 871	-	-
Hole 1.0 mm	-	-	001 999 957	001 999 989	001 999 868	-
Hole 1.5 mm	-	-	001 999 960	001 999 988	-	-
Hole 2.0 mm	001 999 932	-	001 999 959	001 999 987	001 999 867	-
Hole 2.5 mm	-	-	001 999 952	001 999 986	-	-
Hole 3.0 mm	001 999 999	001 999 995	001 999 991	001 999 985	001 999 982	-
Hole 3.5 mm	-	-	001 999 951	-	001 999 924	-
Hole 4.0 mm	001 999 998	001 999 949	001 999 961	-	001 999 973	-
Hole 5.0 mm	001 999 997	-	001 999 958	-	001 999 972	-
Hole 6.0 mm	001 999 996	001 999 994	001 999 990	-	001 999 981	001 999 977
Hole 7.0 mm	-	-	-	-	001 999 971	-
Hole 8.0 mm	-	001 999 993	-	-	001 999 980	001 999 976
Hole 10.0 mm	-	001 999 992	-	-	-	001 999 975
Hole 1/8"	-	-	001 999 964	001 999 983	001 999 979	-
Hole 1/4"	-	-	001 999 965	-	001 999 978	-
Hole 3/32"	-	-	001 999 970	001 999 984	-	-
Collet key	001 365 806 + retaining pin 002 000 069	001 365 811 + retaining pin 002 000 070	007 899 874 (size 9+11 in set)	007 899 751 (size 6+8 in set)	007 899 746 (size 11+14 in set)	007 899 721 (size 14+17 in set)